



Power contactor
BF09

Product designation

Product type designation

Contact characteristics

Number of poles	nr.	4
Rated insulation voltage U_i	V	690
Rated impulse withstand voltage U_{imp}	kV	6
Operating frequency	Operational frequency min	Hz 25
	Operational frequency max	Hz 400
	Conventional free air thermal current I_{th}	A 25
Operating current	Operational current AC1 ($\leq 40^\circ\text{C}$)	A 25
	Operational current AC3 ($\leq 440\text{V} \leq 55^\circ\text{C}$)	A 9
	Operational current AC4 (400V)	A 4.9
	Rated operational power AC1 ($T \leq 40^\circ\text{C}$)	230V kW
400V kW		16
500V kW		21
690V kW		27
Rated operational power AC3A ($T \leq 55^\circ\text{C}$)		Rated operational power AC3 ($T \leq 55^\circ\text{C}$) 230V kW
	Rated operational power AC3 ($T \leq 55^\circ\text{C}$) 400V kW	4.2
	Rated operational power AC3 ($T \leq 55^\circ\text{C}$) 415V kW	4.5
	Rated operational power AC3 ($T \leq 55^\circ\text{C}$) 440V kW	4.8
	Rated operational power AC3 ($T \leq 55^\circ\text{C}$) 500V kW	5.5
	Rated operational power AC3 ($T \leq 55^\circ\text{C}$) 690V kW	7.5
	Short-time allowable current for 10s (IEC/EN60947-1)	A
Protection fuse	gG (IEC)	A 25
	aM (IEC)	A 10
	Making capacity (RMS value)	A 90
Breaking capacity at voltage	Breaking capacity 440V	A 72
	Breaking capacity 500V	A 72
	Breaking capacity 690V	A 71
	Resistance per pole (average value)	m Ω
Power dissipation per pole (average value)	Power dissipation pole (average value) I_{th}	W 1.6
	AC3	W 0.2
	Tightening torque for terminals	min Nm
max Nm		1.8
min lbft		1.1
max lbft		1.5
Tightening torque for coil terminal		

	min	Nm	0.8
	max	Nm	1
	min	lbft	0.8
	max	lbft	0.74
max number of wires simultaneously connectable		nr.	2
Conductor section	AWG		
	min		16
	max		10
Flexible w/o lug conductor section	min	mm ²	1
	max	mm ²	6
Flexible c/w lug conductor section	min	mm ²	1
	max	mm ²	4
Flexible with insulated spade lug conductor section	min	mm ²	1
	max	mm ²	4
Power terminal protection according to IEC/EN 60529			IP20 when wired
Auxiliary contact characteristics			
Operational current AC1 (≤40°C)		A	25
Operating current DC13	110V	A	Screw / DIN rail 35mm
Ambient conditions			
Temperature	Operating temperature		
	min	°C	-50
	max	°C	70
	Storage temperature		
	min	°C	-60
	max	°C	80
Max altitude		m	3000
Operating position	normal allowable		Vertical plan ±30°
Mounting			Screw / DIN rail 35mm
Weight		g	0.368
Operations			
Mechanical life		Cycles	20000000
Electrical life		Cycles	2000000
Safety related data			
Performance level B10d according to EN/ISO 13489-1	rated load mechanical load	Cicli Cicli	2000000 20000000
Mirror contacts according to IEC/EN 60947-4-1			yes
EMC compatibility			yes
AC coil operating			
AC operating voltage	of 50/60Hz coil powered at 50Hz pick-up		
	min	%Us	0.8

		max	%Us	1.1
	drop-out	min	%Us	0.2
		max	%Us	0.55
<hr/>				
of 50/60Hz coil powered at 60Hz				
	pick-up	min	%Us	0.85
		max	%Us	1.1
	drop-out	min	%Us	0.2
		max	%Us	0.55
<hr/>				
of 60Hz coil powered at 60Hz				
	pick-up	min	%Us	0.8
		max	%Us	1.1
	drop-out	min	%Us	0.2
		max	%Us	0.55
<hr/>				
AC operating voltage				
of 50/60Hz coil powered at 50Hz				
		in-rush	VA	75
		holding	VA	9
<hr/>				
of 50/60Hz coil powered at 60Hz				
		in-rush	VA	70
		holding	VA	6.5
<hr/>				
of 60Hz coil powered at 60Hz				
		in-rush	VA	75
		holding	VA	9
<hr/>				
Dissipation at holding $\leq 20^{\circ}\text{C}$ 50Hz			W	2.5
<hr/>				
DC coil operating				
DC rated control voltage				
		max	V	250
<hr/>				
Max cycles frequency				
Mechanical operations			Cycles/h	3600
<hr/>				
Operating times				
Average time for Us control				
in AC				
	Closing NO	min	ms	8
		max	ms	24
	Opening NO	min	ms	10
		max	ms	20
	Closing NC	min	ms	14
		max	ms	28
	Opening NC	min	ms	7
		max	ms	18
<hr/>				
UL technical data				
Full-load current (FLA) for three-phase AC motor				
		at 480V	A	7.6
		at 600V	A	0.375
<hr/>				
Yielded mechanical performance				

for single-phase AC motor

at 110/120V	hp	0.75
at 230V	hp	2

for three-phase AC motor

at 200/208V	hp	3
at 220/230V	hp	3
at 460/480V	hp	5
at 575/600V	hp	7.5

General USE

Contactor

AC current	A	25
------------	---	----

Other features

Pollution degree 3

Dimensions

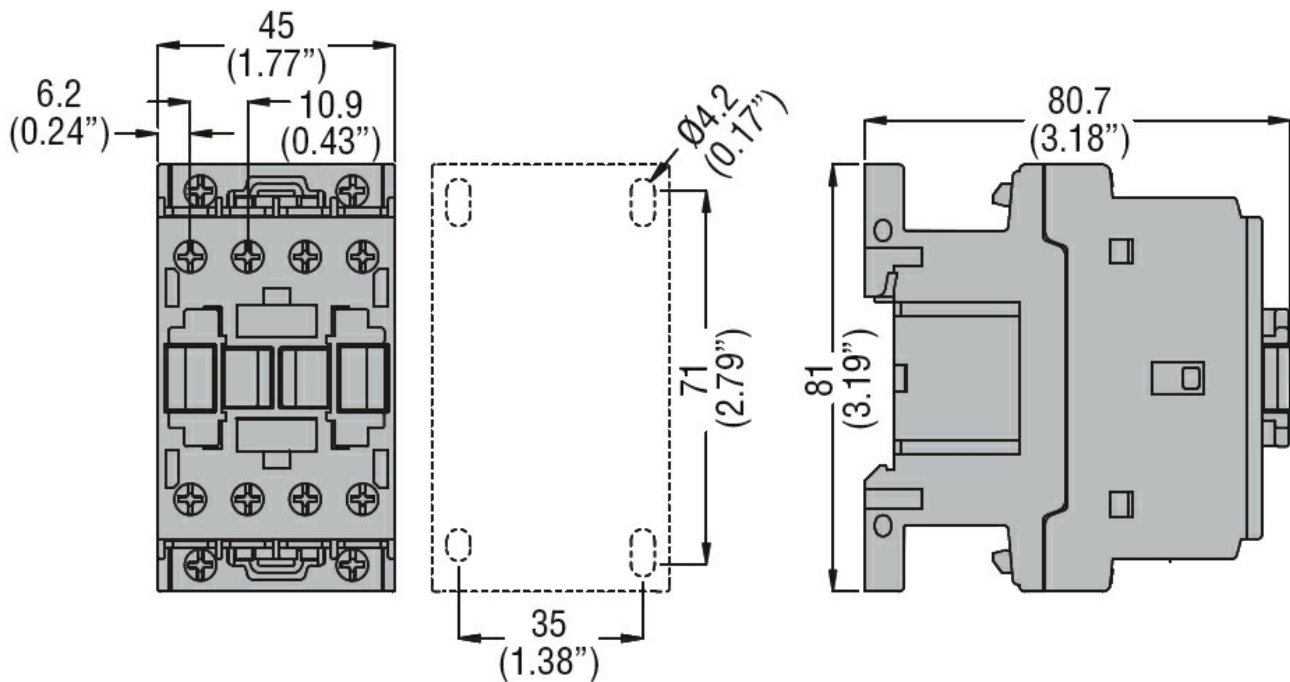

Wiring diagrams

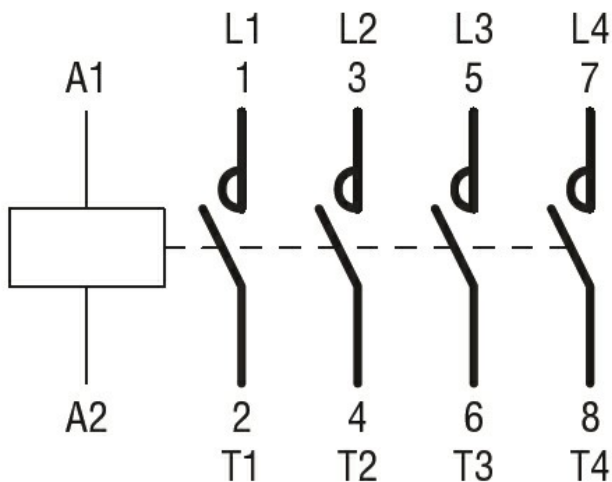

Certifications and compliance

Certifications

CSA C22.2 n° 60947-1

CSA C22.2 n° 60947-4-1

IEC/EN 60947-1

IEC/EN 60947-4-1

UL 60947-1

UL 60947-4-1

Compliance

CCC

cULus

EAC

ETIM 6 classification

EC000066 - Power contactor, AC switching