

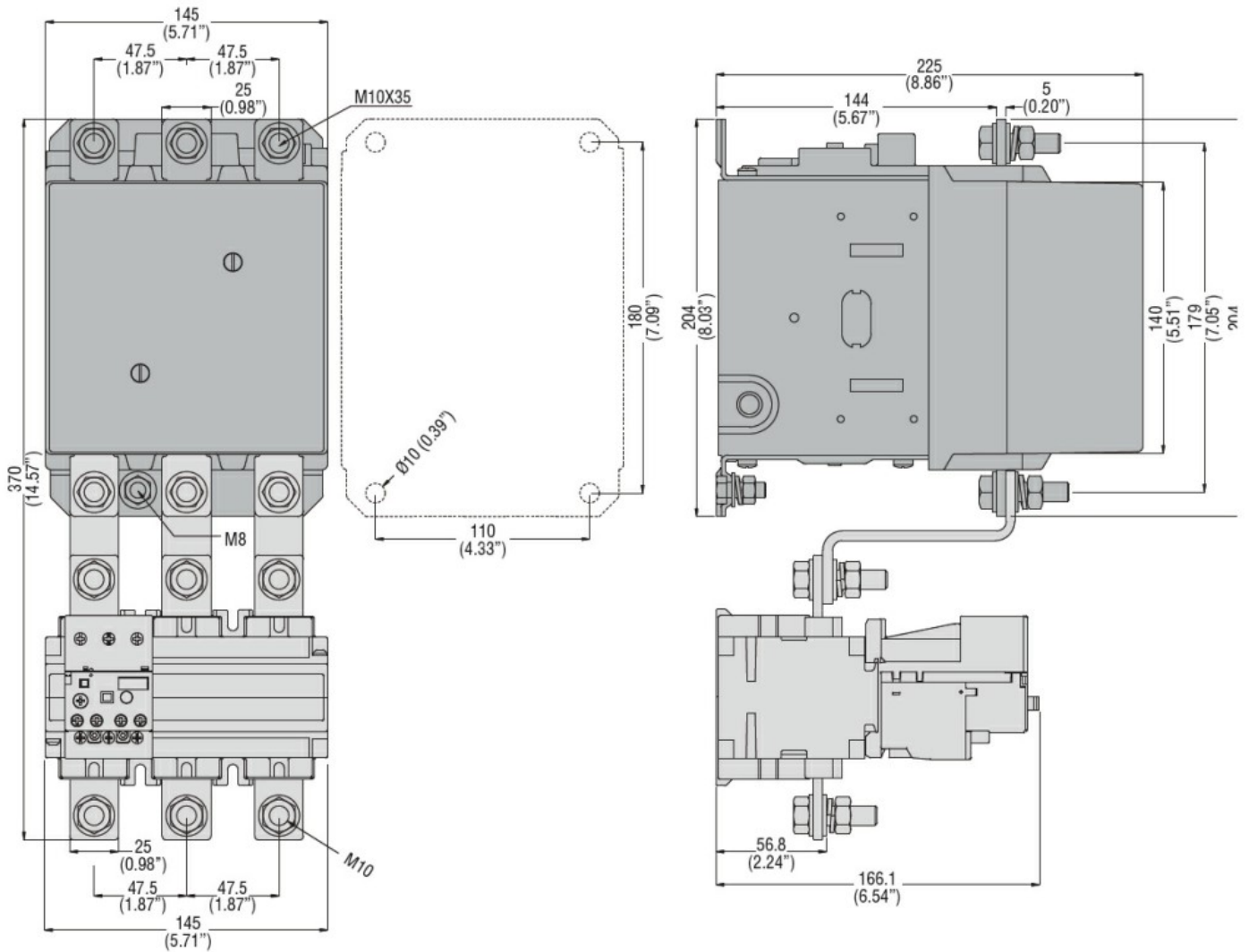

Product designation	Power contactor		
Product type designation	B310		
Contact characteristics			
Number of poles	nr.	3	
Rated insulation voltage U_i	V	1000	
Rated impulse withstand voltage U_{imp}	kV	8	
Operating frequency	Operational frequency min	Hz	25
	Operational frequency max	Hz	400
Conventional free air thermal current I_{th}	A	450	
Operating current	Operational current AC1 ($\leq 40^\circ\text{C}$)	A	450
	Operational current AC3 ($\leq 440\text{V} \leq 55^\circ\text{C}$)	A	320
	Operational current AC4 (400V)	A	110
Rated operational power AC1 ($T \leq 40^\circ\text{C}$)	230V	kW	158
	400V	kW	270
	500V	kW	350
	690V	kW	488
Rated operational power AC3A ($T \leq 55^\circ\text{C}$)	Rated operational power AC3 ($T \leq 55^\circ\text{C}$) 230V	kW	100
	Rated operational power AC3 ($T \leq 55^\circ\text{C}$) 400V	kW	170
	Rated operational power AC3 ($T \leq 55^\circ\text{C}$) 415V	kW	188
	Rated operational power AC3 ($T \leq 55^\circ\text{C}$) 440V	kW	200
	Rated operational power AC3 ($T \leq 55^\circ\text{C}$) 500V	kW	213
	Rated operational power AC3 ($T \leq 55^\circ\text{C}$) 690V	kW	256
	Rated operational power AC3 ($T \leq 55^\circ\text{C}$) 1000V	kW	180
Short-time allowable current for 10s (IEC/EN60947-1)	A	2900	
Protection fuse	gG (IEC)	A	500
	aM (IEC)	A	400
Making capacity (RMS value)	A	3150	
Breaking capacity at voltage	Breaking capacity 440V	A	3000
	Breaking capacity 500V	A	2700
	Breaking capacity 690V	A	2520
Resistance per pole (average value)	m Ω	0.2	
Power dissipation per pole (average value)	Power dissipation pole (average value) I_{th}	W	40.5
	AC3	W	20
Tightening torque for terminals	min	Nm	35
	max	Nm	35
	min	lbft	25.8
	max	lbft	25.8

max number of wires simultaneously connectable		nr.	2
Conductor section	AWG	max	2x 3/0
Power terminal protection according to IEC/EN 60529			IP00
Auxiliary contact characteristics			
Operational current AC1 ($\leq 40^{\circ}\text{C}$)		A	450
Operating current DC13		110V A	Screw
Ambient conditions			
Temperature	Operating temperature	min	$^{\circ}\text{C}$ -50
		max	$^{\circ}\text{C}$ 70
	Storage temperature	min	$^{\circ}\text{C}$ -60
		max	$^{\circ}\text{C}$ 80
Max altitude		m	3000
Operating position		normal allowable	Vertical plan $\pm 30^{\circ}$
Mounting			Screw
Weight		g	9.53
Operations			
Mechanical life		Cycles	10000000
Electrical life		Cycles	700000
Safety related data			
Performance level B10d according to EN/ISO 13489-1		rated load mechanical load	Cicli 700000 Cicli 10000000
Mirror contacts according to IEC/EN 60947-4-1			yes
EMC compatibility			yes
AC coil operating			
AC operating voltage	of 50/60Hz coil powered at 50Hz		
	pick-up	min	%Us 0.8
		max	%Us 1.1
	drop-out	min	%Us 0.2
		max	%Us 0.6
	of 50/60Hz coil powered at 60Hz		
	pick-up	min	%Us 0.8
		max	%Us 1.1
	drop-out	min	%Us 0.2
		max	%Us 0.6
AC operating voltage	of 50/60Hz coil powered at 50Hz		
		in-rush holding	VA 300 VA 10
	of 50/60Hz coil powered at 60Hz		

		in-rush	VA	300
		holding	VA	10
Dissipation at holding ≤20°C 50Hz				
			W	10
DC coil operating				
DC rated control voltage				
		min	V	24
DC operating voltage				
	pick-up			
		min	%Us	0.8
		max	%Us	1.10
	drop-out			
		min	%Us	0.2
		max	%Us	0.60
Average coil consumption ≤20°C				
		in-rush	W	300
		holding	W	10
Max cycles frequency				
Mechanical operations				Cycles/h 2400
Operating times				
Average time for Us control				
	in AC			
		Closing NO		
		min	ms	80
		max	ms	120
		Opening NO		
		min	ms	30
		max	ms	75
	in DC			
		Closing NO		
		min	ms	80
		max	ms	120
		Opening NO		
		min	ms	30
		max	ms	75
UL technical data				
Full-load current (FLA) for three-phase AC motor				
		at 480V	A	301
		at 600V	A	289
Yielded mechanical performance				
	for three-phase AC motor			
		at 200/208V	hp	100
		at 220/230V	hp	125
		at 460/480V	hp	250
		at 575/600V	hp	300
General USE				
	Contactor			
		AC current	A	450
Other features				
Pollution degree				3
Dimensions				



Wiring diagrams

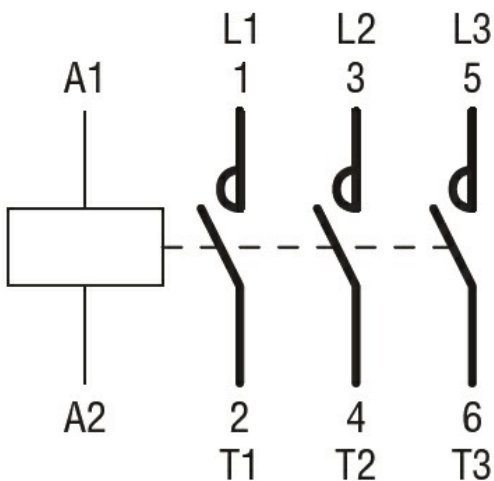

Certifications and compliance

Certifications

- CSA C22.2 n° 60947-1
- CSA C22.2 n° 60947-4-1
- IEC/EN 60947-1
- IEC/EN 60947-4-1
- UL 60947-1

UL 60947-4-1

Compliance

CCC

cULus

EAC

ETIM 6 classification

EC000066 - Power contactor, AC switching